

The European Solar Telescope

Understanding our active Sun

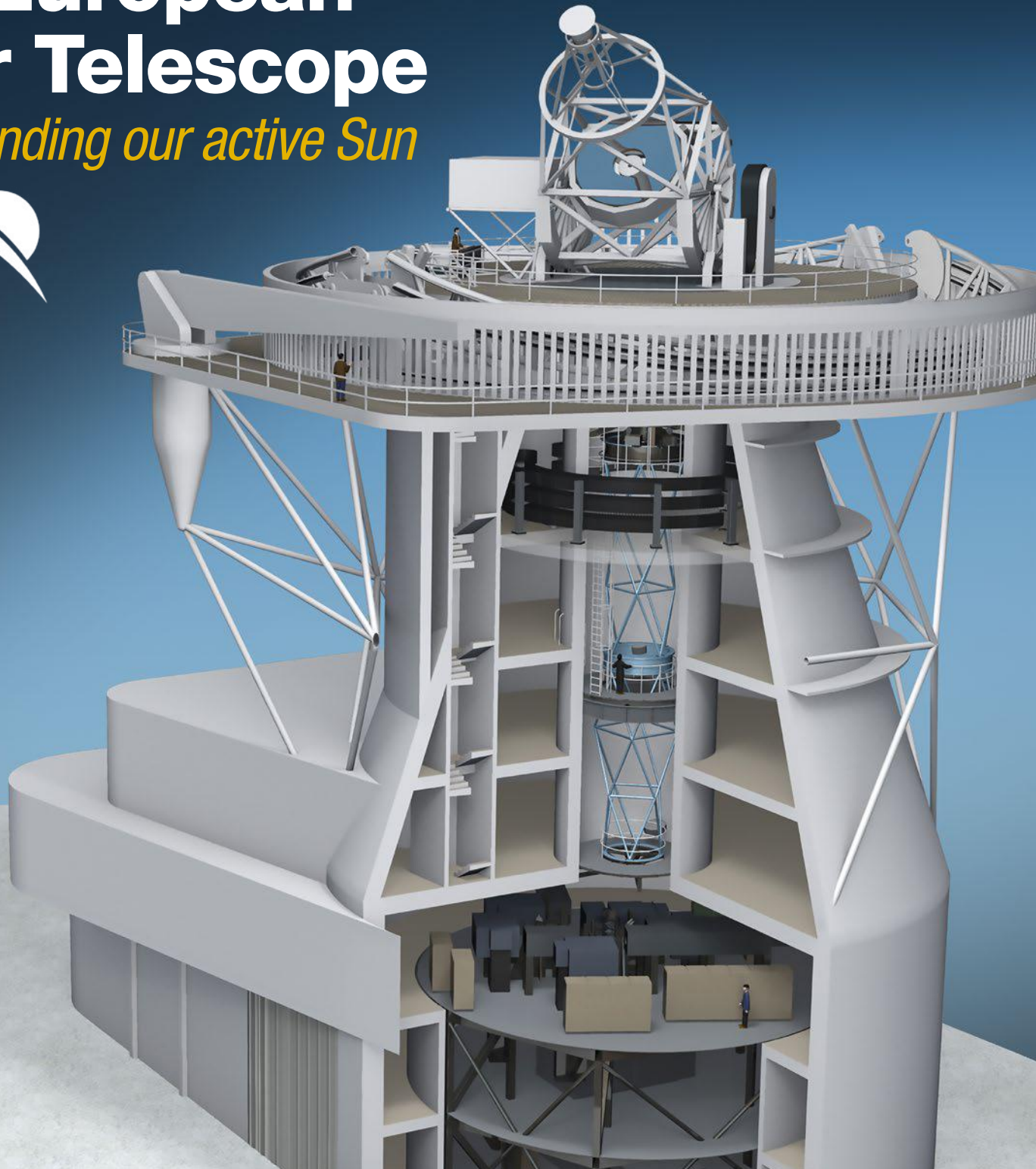

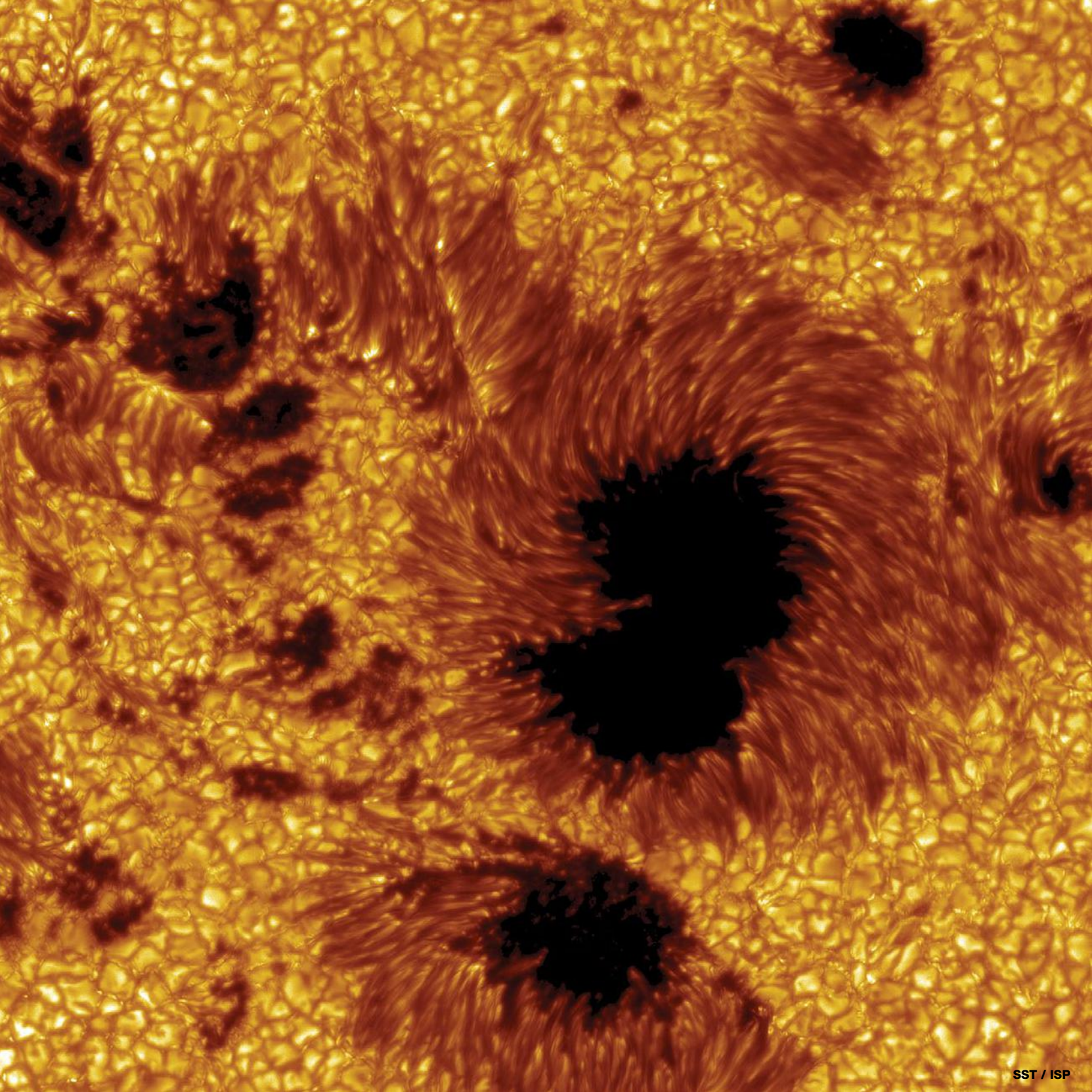

EST

European Solar Telescope

EST, the European Solar Telescope, is a revolutionary 4-metre aperture telescope designed to investigate our active Sun at unprecedented spatial resolution.

Equipped with state-of-the-art instrumentation, it will help scientists understand the magnetic coupling of the solar atmosphere. EST will be installed in the Canary Islands (Spain) to benefit from unique observing conditions. First light is planned for 2027.

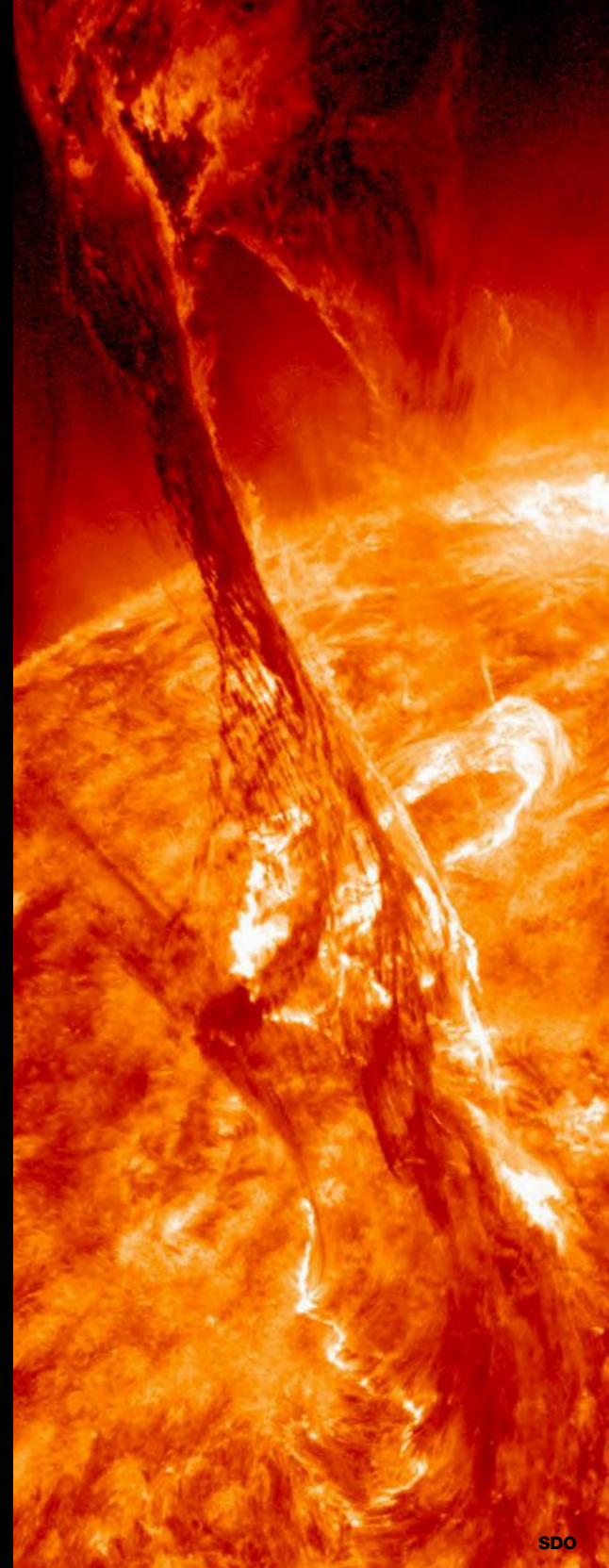

EAST

European Association for Solar Telescopes

The European Association for Solar Telescopes (EAST), founded in 2006 and currently formed by solar physicists from 15 European countries, aims at providing European solar astronomers with access to world-class high-resolution ground-based observing facilities.

In order to achieve that goal, EAST intends to develop, construct and operate a next-generation large-aperture European Solar Telescope (EST) in the Canary Islands. European solar physicists share a consensus about the need for a such next-generation facility and its technical requirements.

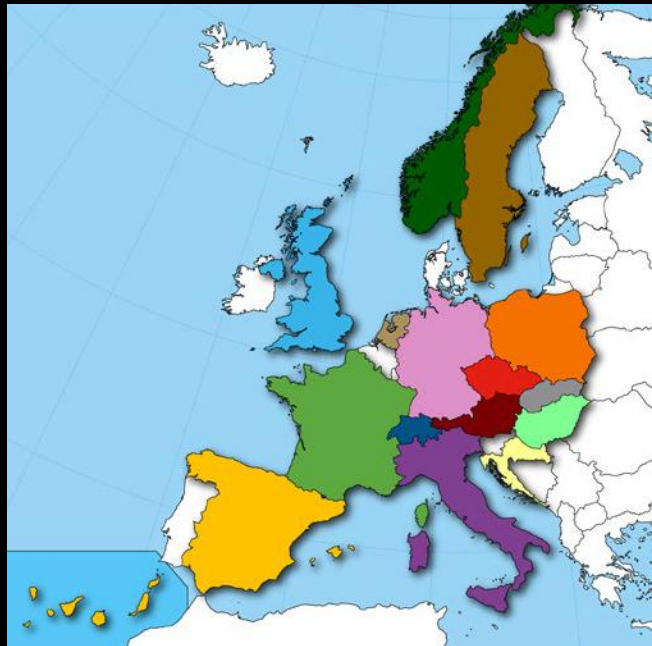

Austria	IGAM	Institutsbereich Geophysik, Astrophysik und Meteorologie der Univ. Graz
Croatia	HVO	Hvar Observatory
Czech Republic	AIASCR	Astronomical Institute AS CR, v.v.i.
France	THEMIS	INSU-CNRS, THEMIS S.L.
Germany	KIS MPS AIP	Kiepenheuer-Institut für Sonnenphysik Max-Planck-Institut für Sonnensystemforschung Leibniz Institut für Sonnenphysik
Great Britain	UCL-MSSL	University College London - MSSL
Hungary	DHO	Debrecen Heliophysical Observatory
Italy	INAF	Istituto Nazionale di Astrofisica University of Catania University of Rome Tor Vergara University of Calabria
Netherlands	UU	Foundation Dutch Open Telescope
Norway	ITA	Institute of Theoretical Astrophysics
Poland	IA UW	Astronomical Institute of the Wroclaw University
Slovakia	AISAS	Astronomical Institute of the Slovak, Academy of Sciences
Spain	IAC IAA	Instituto de Astrofísica de Canarias Instituto de Astrofísica de Andalucía
Sweden	SU	The Institute for Solar Physics
Switzerland	IRSOL	Istituto Ricerche Solari Locarno

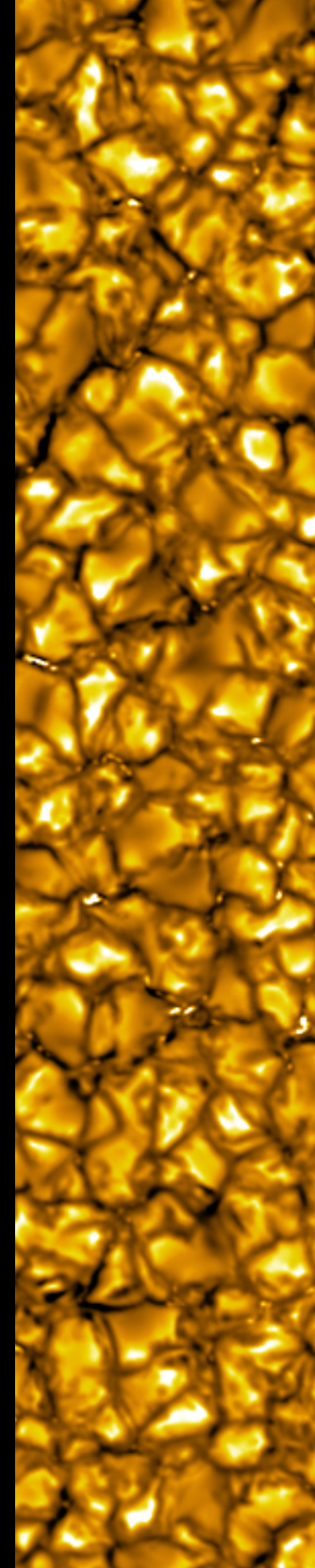

Why study the Sun?

The Sun gives us light and energy, which are indispensable for life on Earth. It is a very dynamic and active system with changes and perturbations that could potentially have dramatic consequences for our civilization. There are many reasons to study the processes taking place on the Sun. Some of them are:

- The Sun is an excellent laboratory of plasma physics, where we can observe interactions between plasmas and magnetic fields in conditions that cannot be reproduced in laboratories or numerical simulations.
- The Sun as a star is a fundamental model for understanding the rest of the Universe. It serves as a reference in terms of chemical composition, structure and evolution models, etc.
- Disturbances in the solar wind buffet the Earth's magnetic field and pump energy into the radiation belts, potentially disrupting satellites, electric power grids or electronic equipment on Earth.
- Its connection with the Earth's climate.

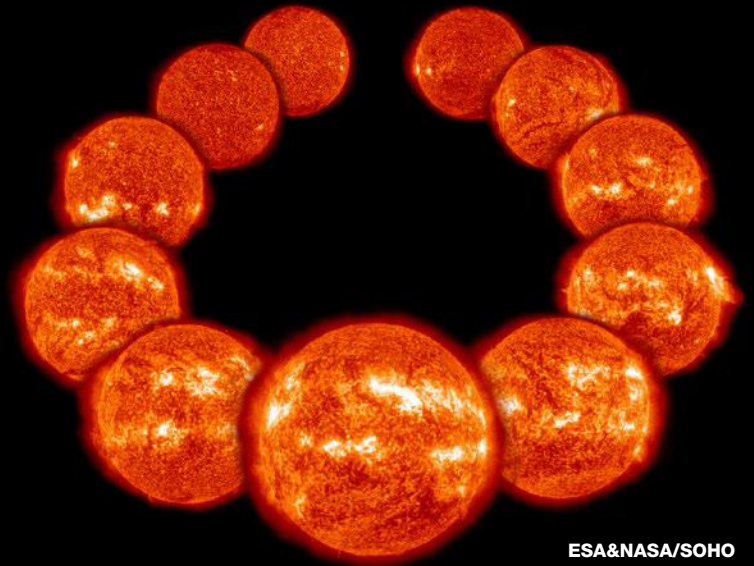

ESA&NASA/SOHO

Eleven years in the life of the Sun, as it progressed from solar minimum to maximum conditions and back to minimum again, seen as a collage of 11 full-disk images of the lower solar corona.

Preparatory Phase



EST has been co-financed by the European Commission and national funding agencies through of several projects.

The EST Preparatory Phase (PRE-EST) has been funded for 4 years under the H2020 Framework Programme. The main objective is to provide both the EST international consortium and the funding agencies with a detailed plan regarding the implementation of EST. In turn, this will provide the necessary information for them to make decisions, addressing both organisational and technical issues as well as costs and risks. Additionally, under PRE-EST the detailed design of EST key elements to the required level of definition and validation for their final implementation will be carried out.

The key goals of PRE-EST are:

LEGAL

- Explore possible legal frameworks and related governance schemes that can be used by agencies to jointly establish, construct and operate EST as a new research infrastructure.

GOVERNANCE

- Explore possible legal frameworks and related governance schemes that provide the means for agencies to jointly establish, construct and operate EST as a new science infrastructure, and to propose an implementation.

FINANCIAL SCHEMES

- Explore funding schemes and funding sources for EST, including a proposal of financial models to make possible the combination of direct financial and in-kind contributions towards the construction and operation of EST.

STRATEGIC ACTIONS

- Engage funding agencies and policy makers for a long-term commitment which guarantees the construction and operation phases of the Telescope;
- Enhance and intensify outreach activities and strategic links with national agencies and the user communities of EST.

TECHNICAL WORK

- Compare the two possible sites for EST in the Canary Islands Astronomical Observatories and prepare final site agreements;
- Involve industry in the design of EST key elements to the required level of definition and validation for their final production.

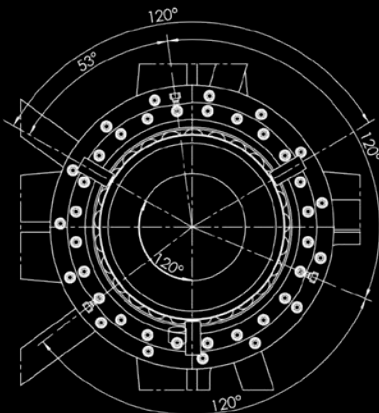
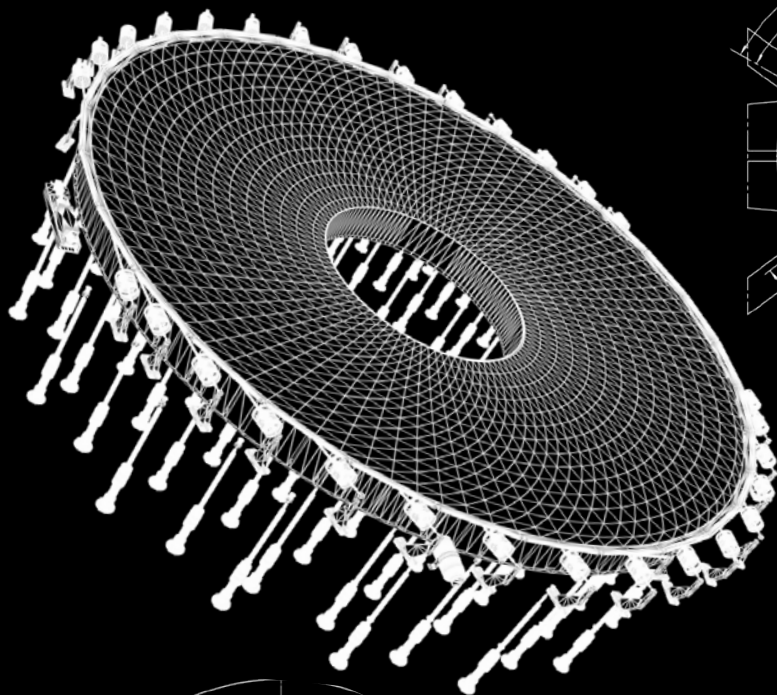

DETAIL D

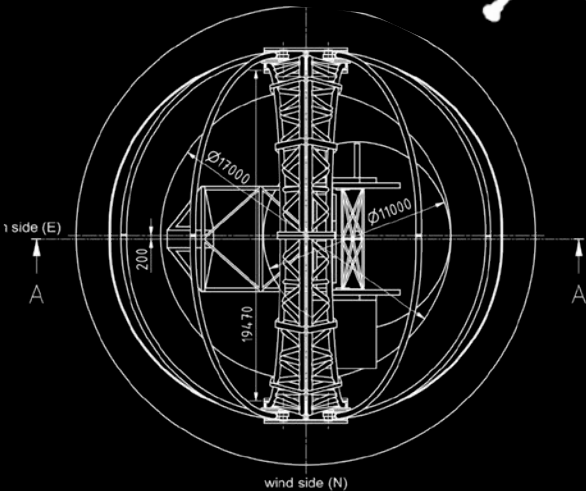
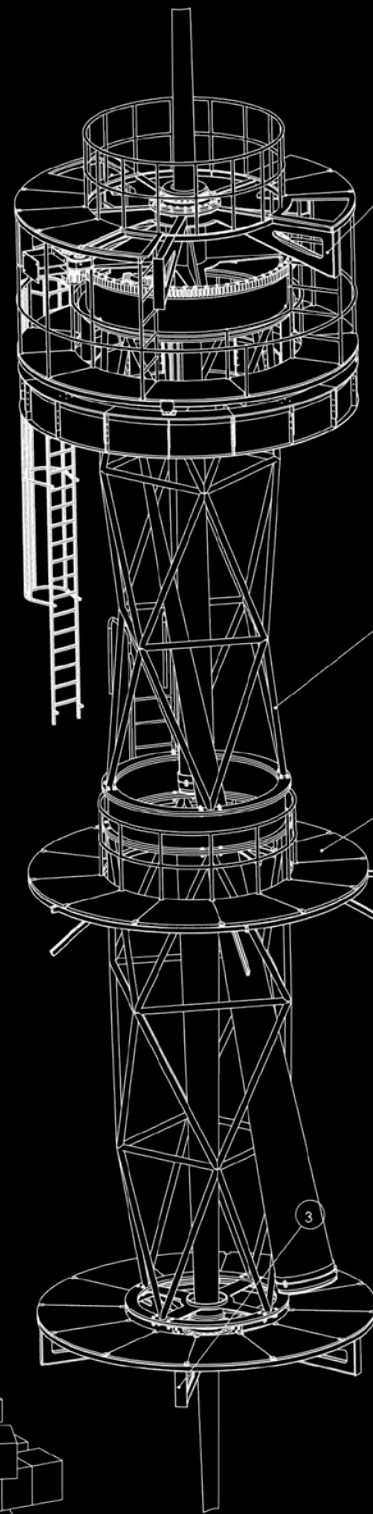

SECTION A-A

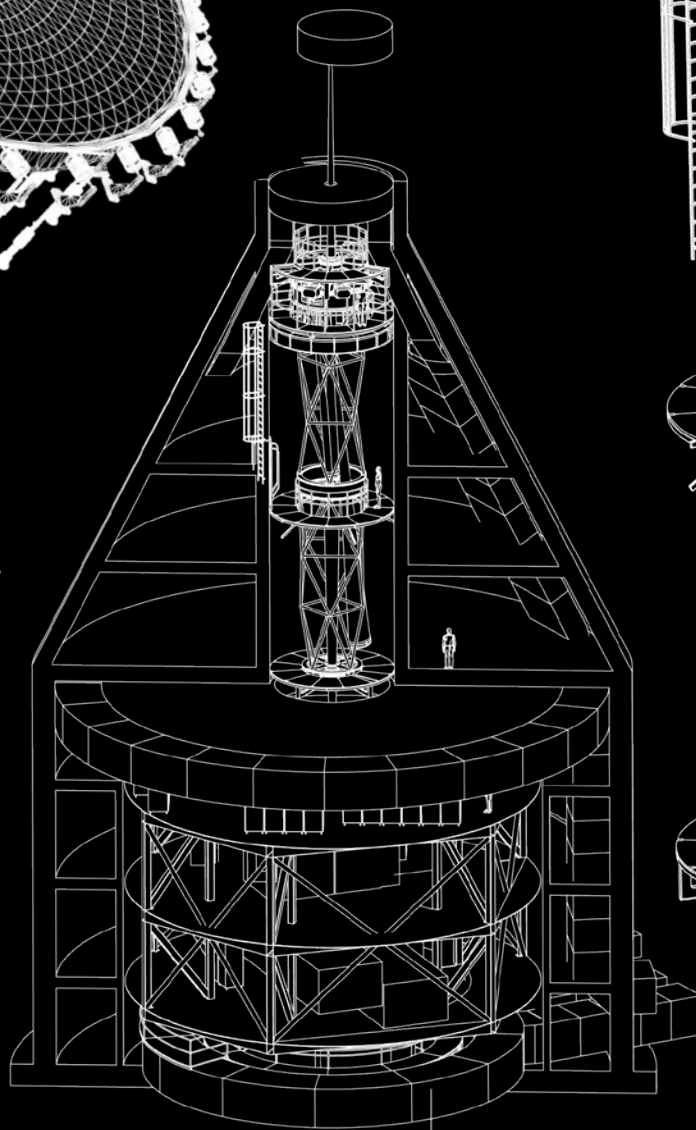
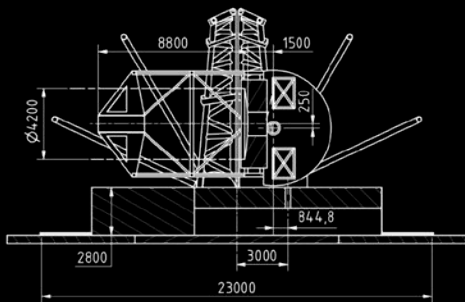

The Canary Islands

Sky protection in the Canary Islands

The Canary Islands observatories (Roque de los Muchachos Observatory on La Palma and Teide Observatory on Tenerife) are first-class locations to host the EST because of the sky quality and excellent conditions for astronomical observations at these sites. Continuous monitoring and characterization of the sky quality has been conducted for many years now. The sky quality is also protected by a National Spanish Law.

The Canary Islands Government supports the construction of EST and has included it in the Regional Research and Innovation Strategy for Smart Specialization (RIS3) as a large-scale infrastructure to be installed in one of the Canarian observatories.

The Spanish Government, at the request of the Canary Islands Parliament, passed the Law for the Protection of the Astronomical Quality of the IAC Observatories (Law 31/88) on the 31st October 1988, and on the 13th March 1992 the Regulations enforcing it (R.D. 243/1992).

The Law contains a range of measures designed to assure the outstanding quality of the observatories of the “Instituto de Astrofísica de Canarias”, as recommended by the International Astronomical Union.

This law makes the IAC’s Observatories a legally protected site (in effect an astronomical “reserve”), where continued dark skies, low radio frequency fields, and control over other sky-polluting effects (including aircraft flight paths) are guaranteed.



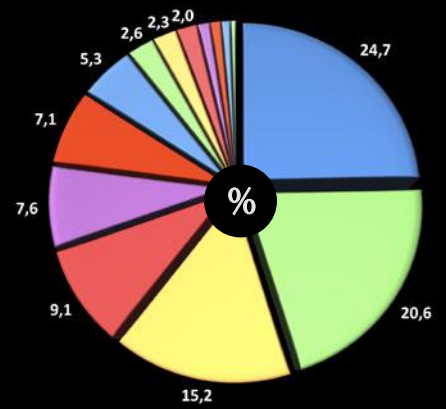
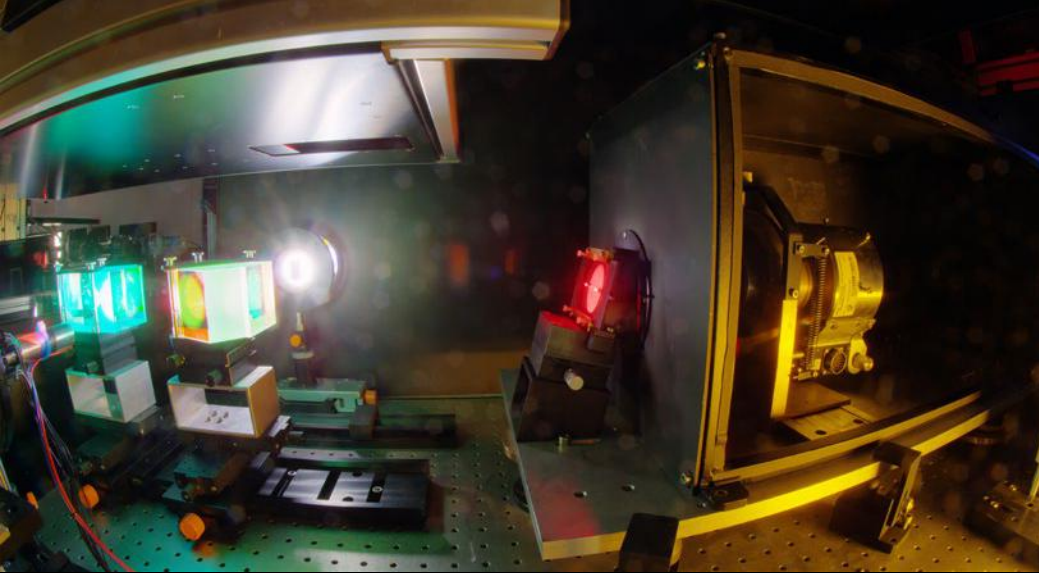

- Optical instrumentation
- Design/manufacturing large mobile structures
- Optics large mirrors
- Software and control system
- Civil Engineering
- Detectors and data acquisition
- Adaptive optics & DM Control
- High precision mechanics and mechatronics
- Design/manufacturing of support structures
- HAVC system (heating, ventilation, air conditioning)
- Optics manufacturing (lens and mirrors, coating, polishing, etc.)
- Cooling systems
- Actuators systems
- Auxiliary services (electrical system, water supply, etc.)

★ Contingency and Project Office costs not included

Opportunities

EST will reinforce Europe's current position in Solar Physics and foster scientific and technological development, with quantifiable economic returns through the creation of highly skilled jobs and increasing the number of special services.

EST's construction will offer unique opportunities for technological developments and industrial contracts. These will enhance European expertise in the design and production of large mirrors, active support systems, thermal control, mechanical structures, adaptive optics, large format high-speed detectors, high-precision scientific instrumentation or data management systems.

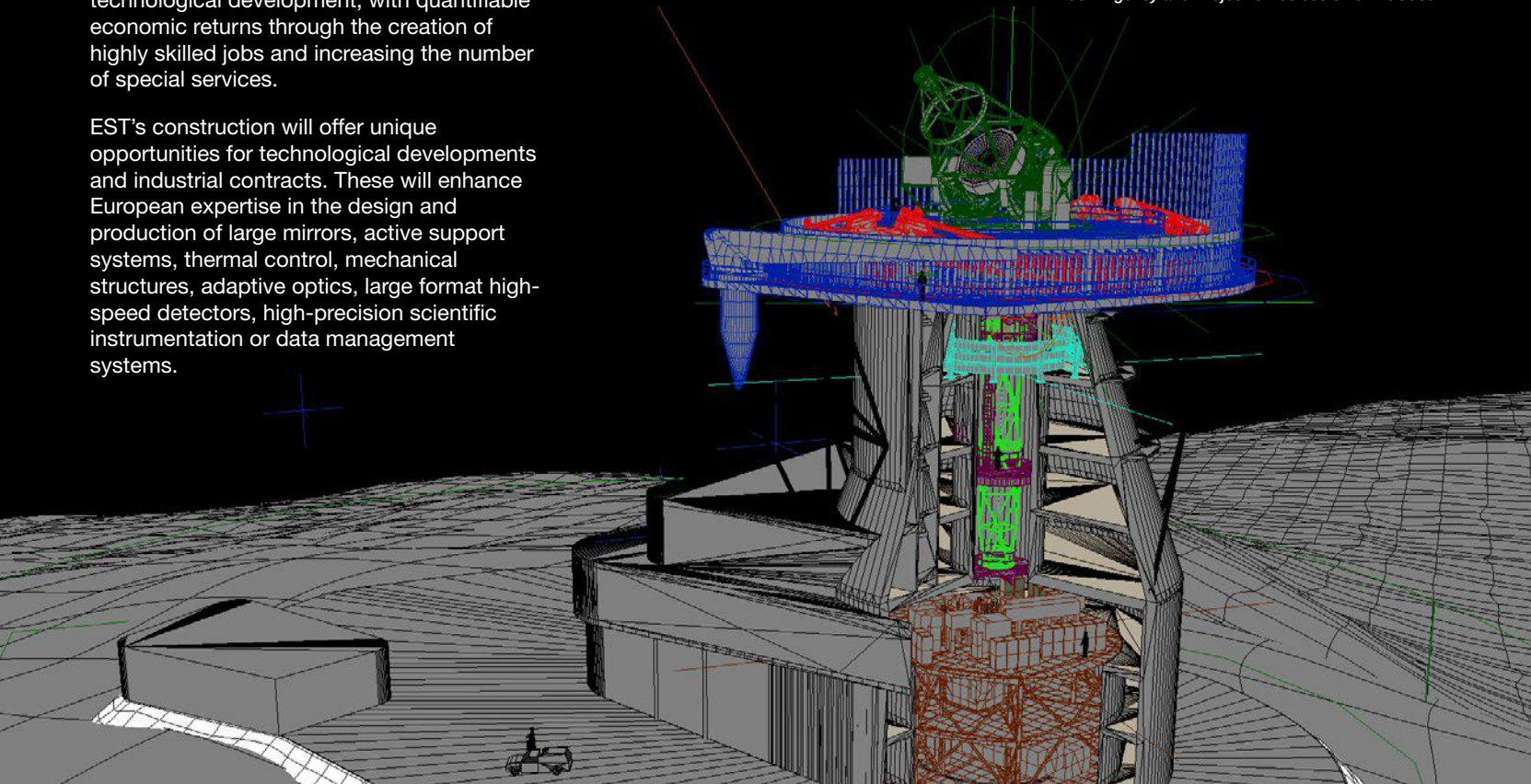

EST as ESFRI project

ESFRI (European Strategy Forum on Research Infrastructures) is a strategic instrument to develop the scientific integration of Europe and to strengthen its international outreach.

The EST project was included in the ESFRI Roadmap 2016 update.

This new achievement implies a major boost towards the assurance of the financial feasibility of this trans-national project, as well as priority within the corresponding national policies on large-scale research infrastructures.

EST Timeline: Design, construction and operation

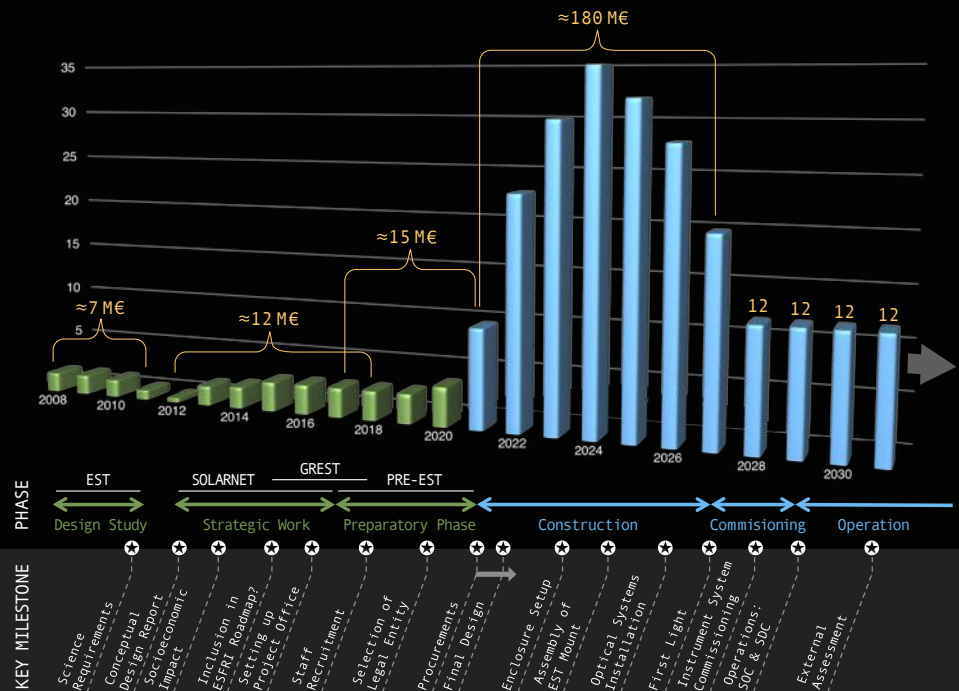

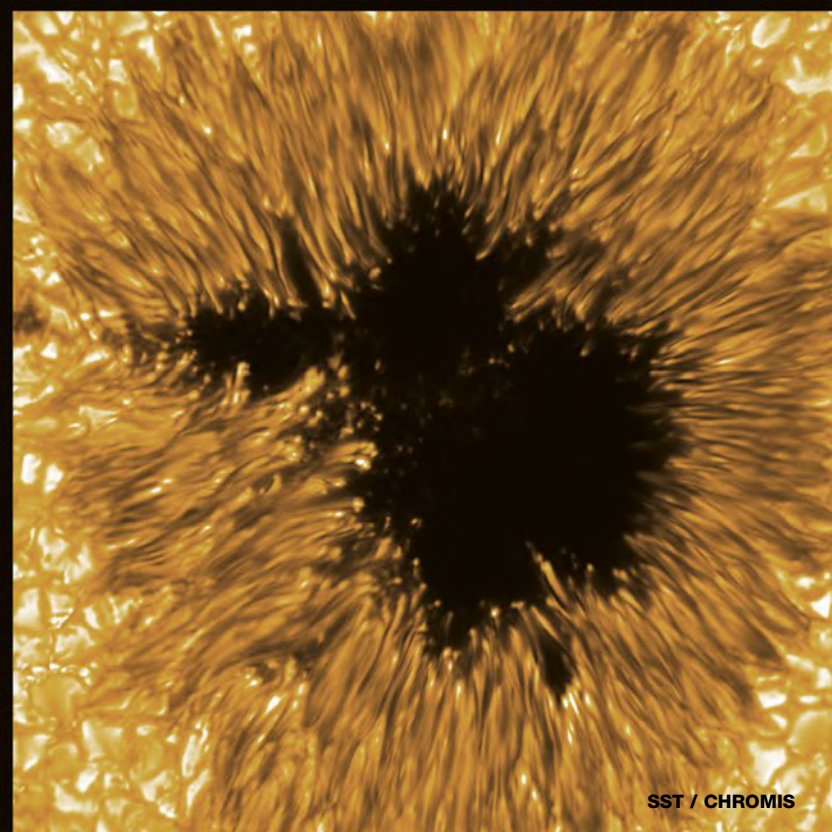
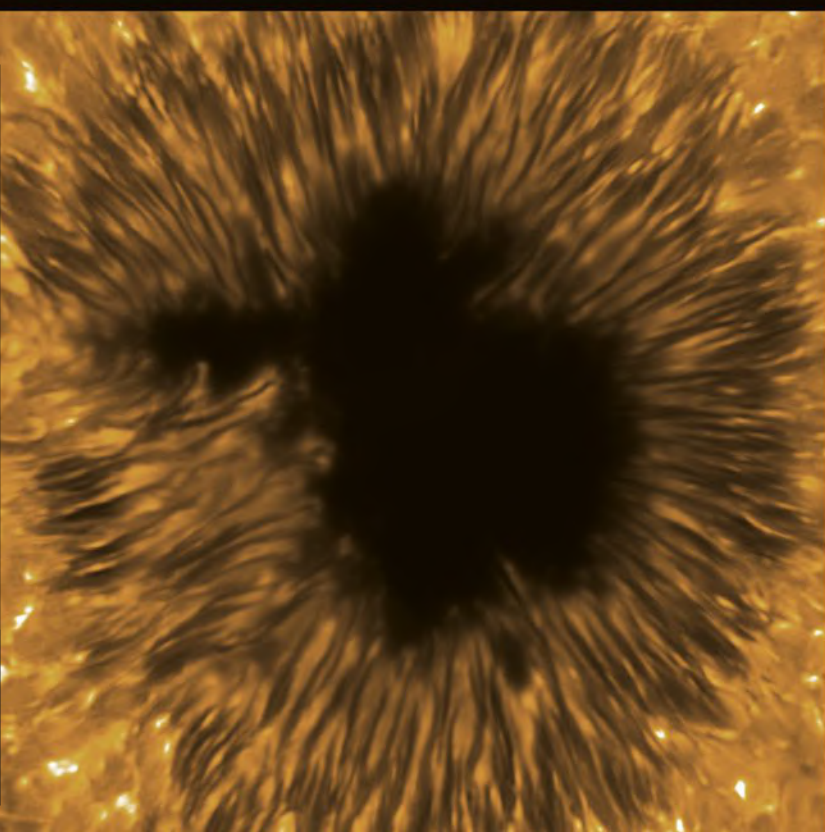
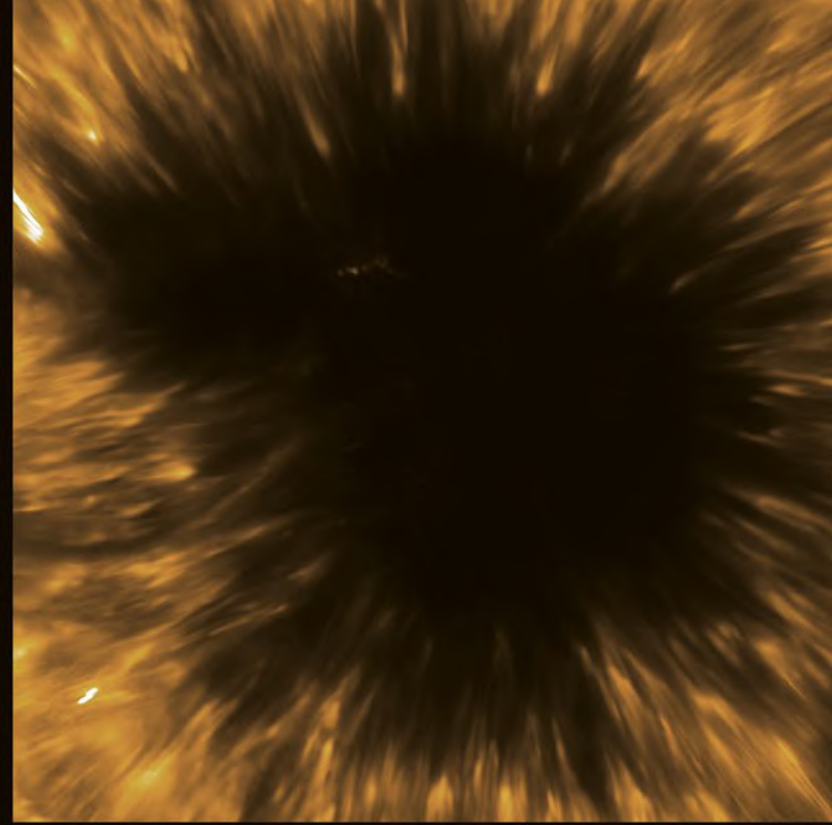
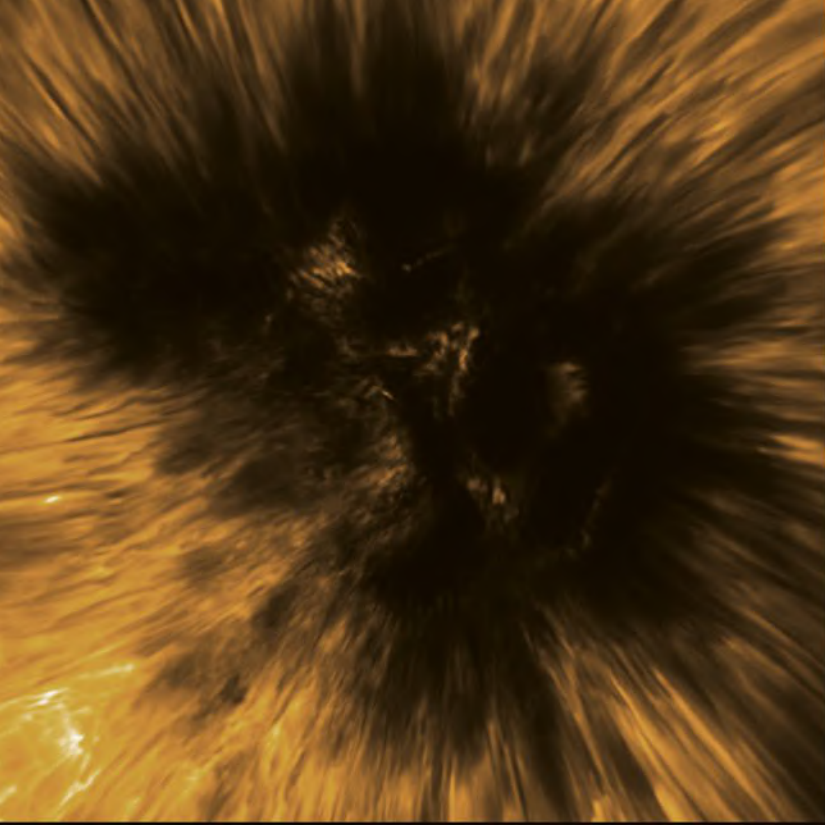



more information:

www.est-east.eu

Instituto de Astrofísica de Canarias (IAC)
C/ Vía Láctea s/n, La Laguna
SPAIN

+34 922 605 200 / fax +34 922 605 210
e-mail est-east@iac.es



The EST Conceptual Design Study and SOLARNET have been co-financed by the European Commission's FP7, while GREY and PRE-EST are projects co-financed by the H2020 Programme. Moreover, the European Regional Development Fund (ERDF) will also contribute to the Preparatory Phase of EST together with national funding agencies.